



TREMLOCK ECO EDGE EXTENDED FASCIA BUR/MB

BUILT-UP OR MODIFIED VERSION

INSTALLATION INSTRUCTIONS

TYPICAL INSTALLATION FOR 12'-0" STRAIGHT COVER

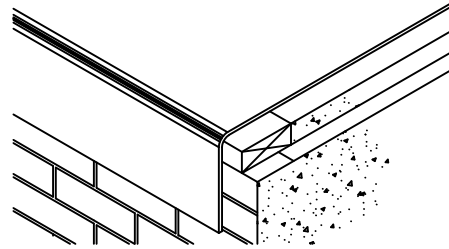
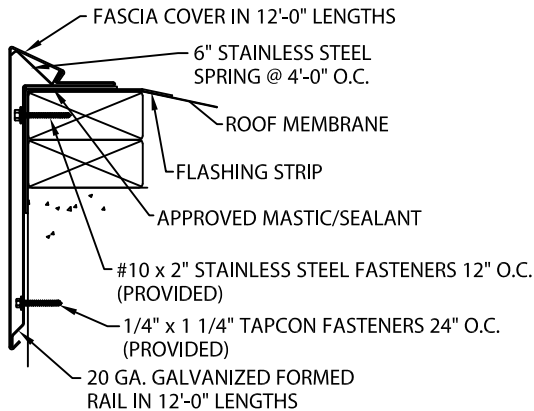

STEP 1 - MEMBRANE

POSITION BASE SHEET OF THE BUILT-UP OR MODIFIED ROOFING MEMBRANE OVER THE ROOF EDGE COVERING NAILS COMPLETELY.

NOTE: FOLLOW GENERAL RECOMMENDATIONS OF TREMCO'S APPLICATION OF THE MEMBRANE OVER THE EDGE.

CAUTION: TAKE EXTREME CARE TO AVOID SPILLAGE OF THE ASPHALT OVER THE EDGE

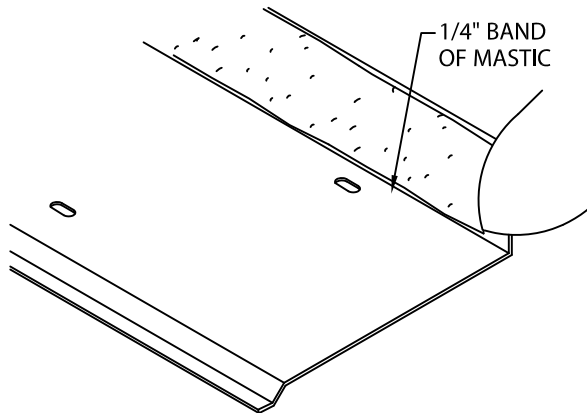

BASE RAIL SHOWN WITH INSIDE FACE UP.

STEP 2 - BASE RAIL (PREPARATION)

LAY THE BASE RAIL ON THE DECK WITH THE OUTSIDE FACE DOWN. IF NECESSARY, CLEAN THE BACK SIDE OF THE BASE RAIL OF DUST OR DIRT. APPLY A HEAVY 1/4" BAND OF MASTIC /SEALANT TO THE BACK OF THE DECK FLANGE FOR THE ENTIRE LENGTH OF THE RAIL AS SHOWN

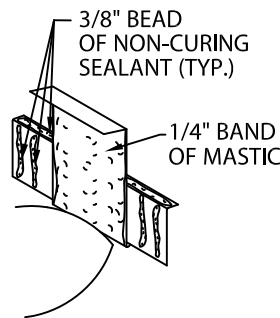

STEP 3 - BASE RAIL SPLICE PLATE

APPLY A HEAVY 1/4" BAND OF APPROVED MASTIC/SEALANT TO THE BOTTOM OF THE 2" WIDE DECK FLANGE OF THE RAIL SPLICE PLATE AS SHOWN.

NEXT, APPLY 3/8" BEADS OF NON-CURING SEALANT TO TOP AND SIDES OF THE RAIL SPLICE AS SHOWN.



PHONE: 800-558-2162
EDGESYSTEMS@TREMCOINC.COM
WWW.TREMCOROOFING.COM

DATE: 07/21/18
DRN BY: JJC
CKD BY: SAK

SHT.# 1 OF 5
DWG# 60110-29299

A



TREMLOCK ECO EDGE EXTENDED FASCIA BUR/MB

BUILT-UP OR MODIFIED VERSION

INSTALLATION INSTRUCTIONS

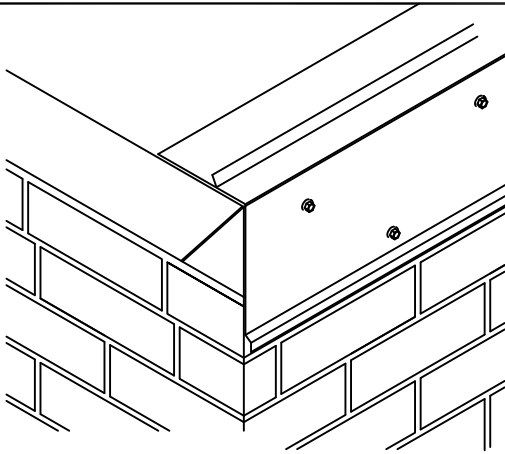

STEP 4 - OUTSIDE MITERS

ON THE BUILDING CORNER, IDENTIFY THE "DOG EAR" OR THE OVERLAP OF THE FLASHING STRIP. FASTEN A 12'-0" SECTION OF BASE RAIL, PREPARED WITH MASTIC/SEALANT AS SHOWN IN STEP #2, TO THE OPPOSITE FACE, WITH THE END EVEN WITH THE EDGE OF THE WALL. FASTEN IN PLACE THROUGH THE RAIL SLOTS 12" O.C. WITH PROVIDED FASTENERS.

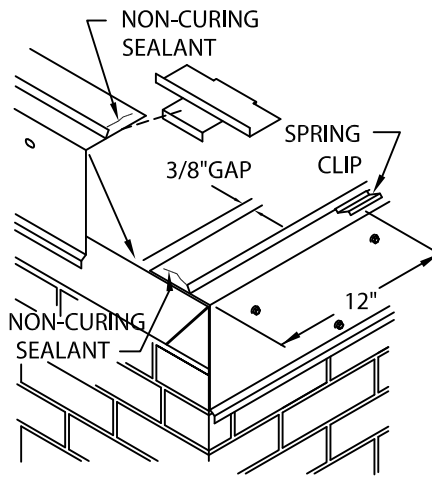

STEP 5 - OUTSIDE MITERS

APPLY NON-CURING SEALANT ADJOINING ENDS OF BASE RAIL AS SHOWN. SLIDE BASE RAIL SPLICE PLATE OVER THE EDGE OF 12'-0" RAIL SECTION. INSTALL RAIL SECTION TO "DOG EAR" SIDE OF THE WALL, LEAVING A 3/8" GAP TO ADJOINING RAIL. FASTEN TO NAILER THROUGH SLOTS 12" O.C. & 24" O.C. WITH PROVIDED FASTENERS. FIELD CUT AS NEEDED. LOCATE 6" SPRING CLIPS AT MITER COVER SPLICE PLATE OR NO FURTHER THAN 12" FROM CORNER. THEN 4'-0" O.C., MAKING SURE THERE WILL BE A SPRING CLIP UNDER EACH FASCIA COVER END.

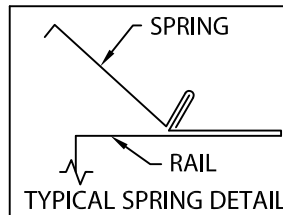

TYPICAL SPRING DETAIL

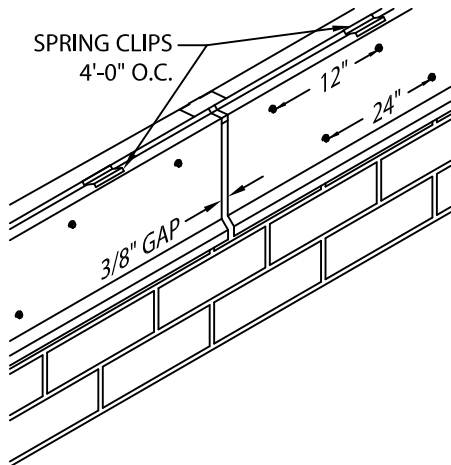

STEP 6 - BASE RAIL INSTALLATION

INSTALL 12'-0" SECTIONS OF BASE RAIL WITH NON-CURING SEALANT AS SHOWN IN STEP 2. INSTALL BASE RAIL SPLICE PLATE ONTO THE END OF RAIL SECTION TO THE HALFWAY POINT OF THE SPLICE PLATE FLANGE. INSTALL BASE RAIL FROM RIGHT TO LEFT, (AS SEEN FROM ROOF TOP). LEAVE A 3/8" GAP BETWEEN RAIL SECTIONS. FASTEN RAIL TO NAILER THROUGH SLOTS 12" O.C. WITH PROVIDED FASTENERS. FIELD CUT BASE RAIL SECTIONS AS NEEDED.

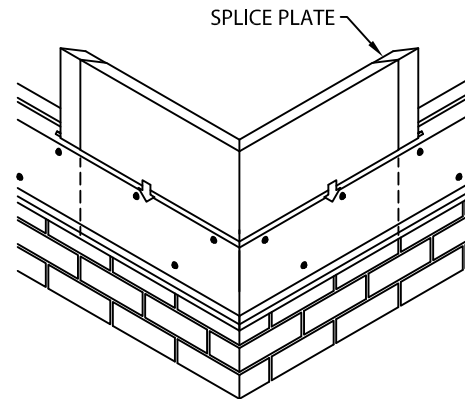

STEP 7 - MITERS

PLACE SPLICE PLATE INTO EACH END OF MITER COVER. SIMPLY POSITION THE COVER ATOP RAIL AND WITH PALM OF HAND APPLY SLIGHT PRESSURE DOWNWARD UNTIL ENGAGED TO BASE RAIL. IF MITERS ARE NOT SUPPLIED, SEE PAGE 5 FOR FABRICATION INSTRUCTIONS.



PHONE: 800-558-2162
EDGESYSTEMS@TREMCOINC.COM
WWW.TREMCOROOFING.COM

DATE: 07/21/18
DRN BY: JJC
CKD BY: SAK

SHT.# 2 OF 5
DWG# 60110-29299

A



TREMLOCK ECO EDGE EXTENDED FASCIA BUR/MB

BUILT-UP OR MODIFIED VERSION

INSTALLATION INSTRUCTIONS

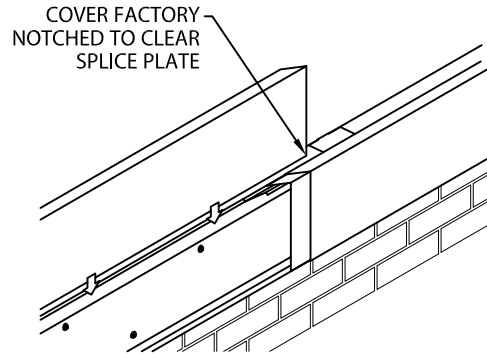
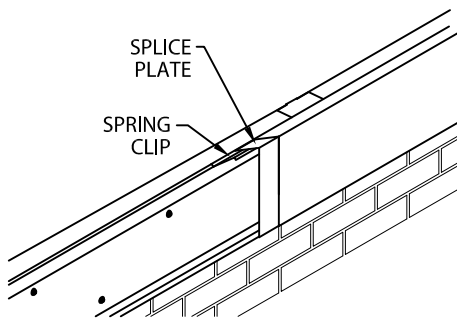

STEP 8 - FASCIA COVER

REMOVE THE PROTECTIVE FILM FROM FASCIA COVERS. POSITION 12'-0" FASCIA COVERS ON TOP OF BASE RAIL. FASCIA COVERS SHALL BE INSTALLED FROM LEFT TO RIGHT AS SEEN FROM ROOFTOP. PLACE SPLICE PLATE IN RIGHT END OF COVER. SNAP RIGHT COVER ONTO BASE RAIL BY APPLYING DOWNWARD PRESSURE WITH PALM OF HAND UNTIL THE FASCIA COVER IS FULLY ANGAGED ALONG ENTIRE LENGTH. FIELD CUT COVERS AS REQUIRED WITH FINE TOOTH HACKSAW.

STEP 9 - FASCIA COVER

POSITION PRE-NOTCHED COVER AND SNAP ONTO BASE RAIL BY BYPRESSING DOWN WITH THE PALM OF YOUR HAND UNTIL THE COVER IS FULLY ENGAGED ALONG THE ENTIRE LENGTH. ALLOW A 3/8" GAP BETWEEN COVER SECTIONS. FIELD CUT WHERE NECESSARY USING A FINE TOOTH HACKSAW.

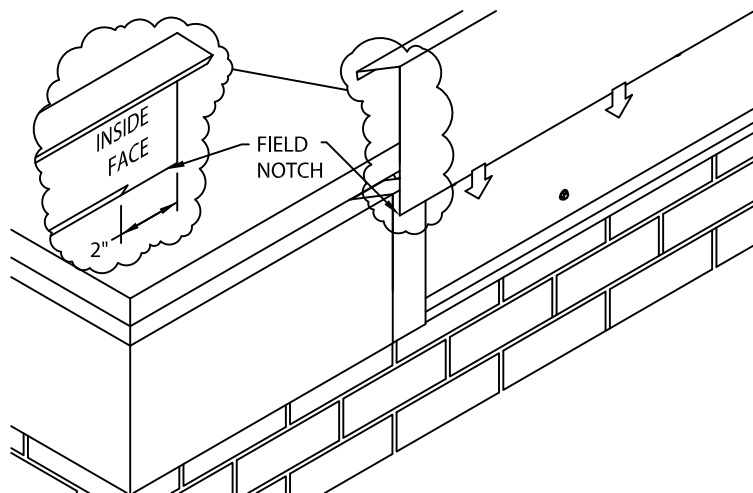

STEP 10 - FASCIA COVER

AT MITER, FIELD NOTCH RIGHT SIDE OF COVER AS SHOWN. SNAP ONTO BASE RAIL BY PRESSING DOWN WITH THE PALM OF YOUR HAND UNTIL THE COVER IS FULLY ENGAGED ALONG THE ENTIRE LENGTH. ALLOW 3/8" BETWEEN COVER SECTIONS. FIELD CUT WHERE NECESSARY USING THE FINE TOOTH HACKSAW.



PHONE: 800-558-2162
EDGESYSTEMS@TREMCOINC.COM
WWW.TREMCOROOFING.COM

DATE: 07/21/18
DRN BY: JJC
CKD BY: SAK

SHT.# 3 OF 5
DWG# 60110-29299

A



TREMLOCK ECO EDGE EXTENDED FASCIA BUR/MB

BUILT-UP OR MODIFIED VERSION

INSTALLATION INSTRUCTIONS

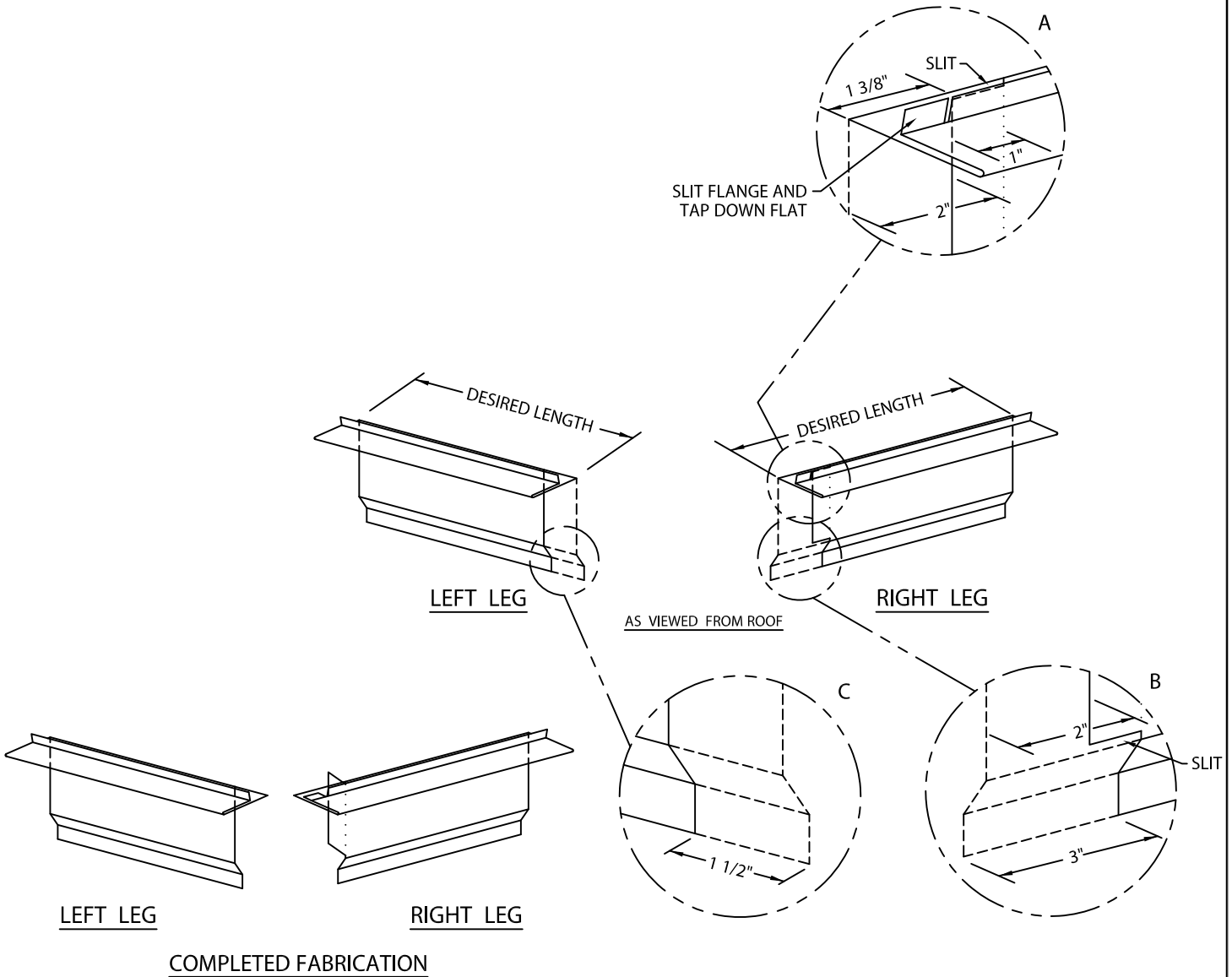

STEP 11 - INSIDE MITER RAIL FABRICATION (CUT RAIL TO DESIRED LENGTH)

FOR RIGHT LEG-SEE DETAIL A: ON THE TOP FLANGE CUT SLIT 1 3/8" FROM THE END AND TAP DOWN FLAT. TRIM BACK THE FRONT FACE 2" AND SLIT FACE 1" AS SHOWN.

DETAIL B: ON THE BOTTOM FLANGE TRIM BACK 3". SLIT FACE 1" CREATING A 1" TAB. BEND THE TAB OUTWARDS 90°.

FOR LEFT LEG- DETAIL C: TRIM ENTIRE FACE AND BOTTOM FLANGE BACK 1 1/2" AS SHOWN.



PHONE: 800-558-2162
EDGESYSTEMS@TREMCOINC.COM
WWW.TREMCOROOFING.COM

DATE: 07/21/18
DRN BY: JJC
CKD BY: SAK

SHT.# 4 OF 5
DWG# 60110-29299

A



TREMLOCK ECO EDGE EXTENDED FASCIA BUR/MB

BUILT-UP OR MODIFIED VERSION

INSTALLATION INSTRUCTIONS

STEP 12 - OUTSIDE MITER COVER FABRICATION (CUT COVER TO DESIRED LENGTH)

RIGHT LEG - DETAIL A: CREATE TAB BY REMOVING 1" PORTION OF TOP FLANGE AND EXTEND REMOVAL 1/8" DOWN FACE. DETAIL B: CUT TOP FLANGE AT ANGLE 2" AS SHOWN. DETAIL C: CUT LOWER FLANGE AT AN ANGLE 3/4" AS SHOWN. BEND 1" TAB 90° INWARD AS SHOWN.

LEFT LEG - DETAIL D: CUT TOP FLANGE AT ANGLE 2" AS SHOWN. DETAIL E: CUT LOWER FLANGE AT AN ANGLE 3/4" AS SHOWN.

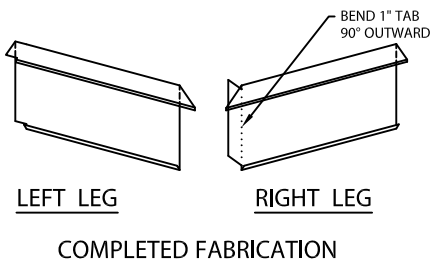
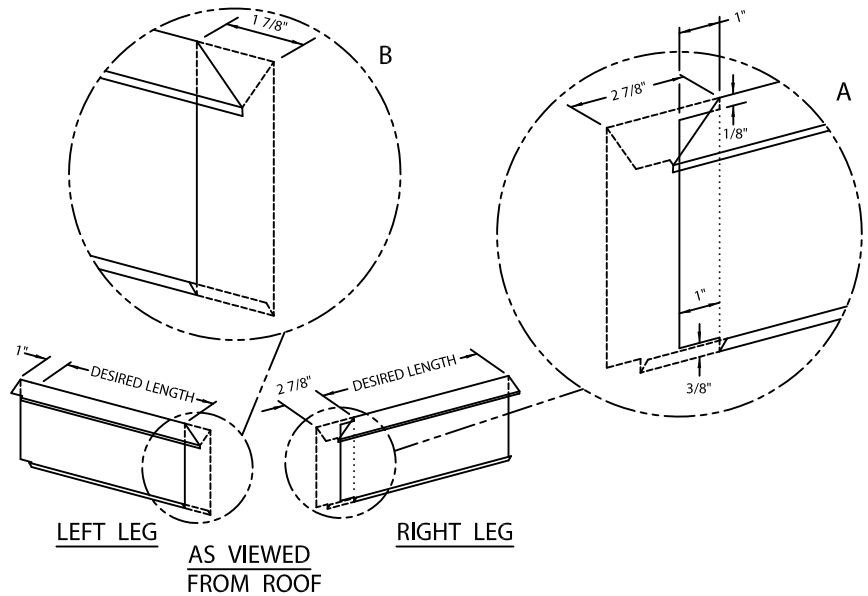
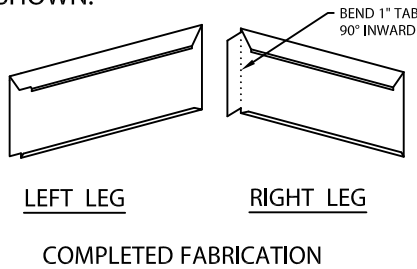
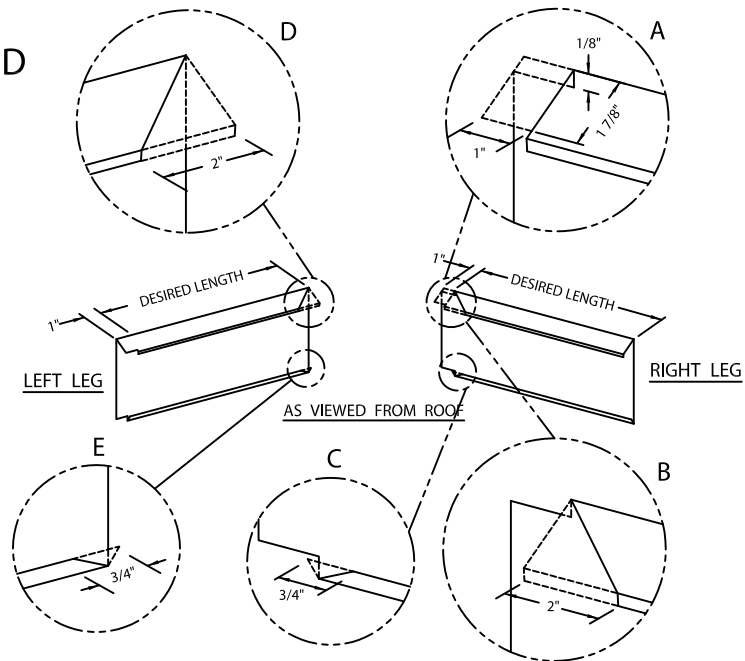

STEP 13 - INSIDE MITER COVER FABRICATION (CUT COVER TO DESIRED LENGTH)

RIGHT LEG - DETAIL A: CREATE TAB BY CUTTING TOP FLANGE AT ANGLE 2 7/8" AS SHOWN. CUT 1/8" DOWN FACE AND 1" HORIZONTALLY. CUT DOWNWARD THROUGH FACE AND CONTINUE CUTTING TO WITHIN 3/8" FROM BOTTOM FLANGE. CUT 1" HORIZONTALLY AS SHOWN, THEN CUT THROUGH BOTTOM FLANGE. BEND 1" TAB 90° OUTWARD AS SHOWN.

LEFT LEG : DETAIL B: TRIM BACK THE TOP FLANGE ON ANGLE 1 7/8". PROCEED CUTTING THROUGH FRONT FACE AS SHOWN.



PHONE: 800-558-2162
 EDGESYSTEMS@TREMCOINC.COM
 WWW.TREMCOROOFING.COM

DATE: 07/21/18
 DRN BY: JJC
 CKD BY: SAK

SHT.# 5 OF 5
 DWG# 60110-29299

A